

Please check the examination details below before entering your candidate information

Candidate surname

Other names

**Pearson Edexcel
International GCSE**

Centre Number

--	--	--	--	--

Candidate Number

--	--	--	--	--

Thursday 6 June 2019

Morning (Time: 2 hours)

Paper Reference **4MA1/2H**

Mathematics A

Level 1/2

Paper 2H

Higher Tier



You must have:

Ruler graduated in centimetres and millimetres, protractor, compasses, pen, HB pencil, eraser, calculator. Tracing paper may be used.

Total Marks

Instructions

- Use **black** ink or ball-point pen.
- **Fill in the boxes** at the top of this page with your name, centre number and candidate number.
- Answer **all** questions.
- Without sufficient working, correct answers may be awarded no marks.
- Answer the questions in the spaces provided
– *there may be more space than you need.*
- **Calculators may be used.**
- You must **NOT** write anything on the formulae page.
Anything you write on the formulae page will gain NO credit.

Information

- The total mark for this paper is 100.
- The marks for **each** question are shown in brackets
– *use this as a guide as to how much time to spend on each question.*

Advice

- Read each question carefully before you start to answer it.
- Check your answers if you have time at the end.

Turn over ►

P58371A

©2019 Pearson Education Ltd.

1/1/1



Pearson

International GCSE Mathematics

Formulae sheet – Higher Tier

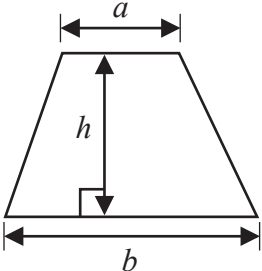
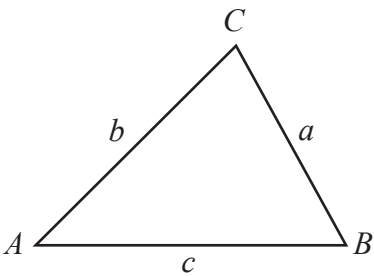
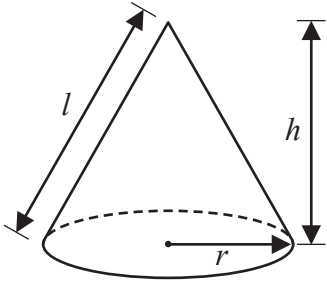
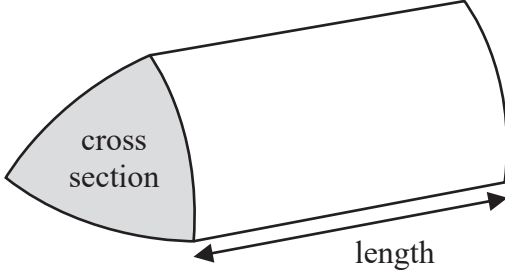
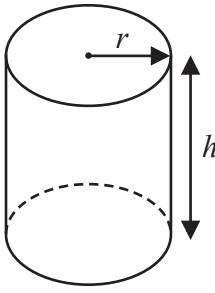
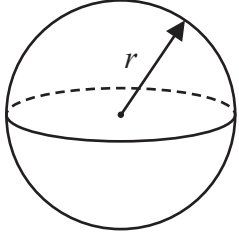
<p>Arithmetic series Sum to n terms, $S_n = \frac{n}{2} [2a + (n - 1)d]$</p>	<p>Area of trapezium = $\frac{1}{2}(a + b)h$</p>
<p>The quadratic equation The solutions of $ax^2 + bx + c = 0$ where $a \neq 0$ are given by: $x = \frac{-b \pm \sqrt{b^2 - 4ac}}{2a}$</p>	
<p>Trigonometry</p> 	<p>In any triangle ABC Sine Rule $\frac{a}{\sin A} = \frac{b}{\sin B} = \frac{c}{\sin C}$ Cosine Rule $a^2 = b^2 + c^2 - 2bc \cos A$ Area of triangle = $\frac{1}{2} ab \sin C$</p>
<p>Volume of cone = $\frac{1}{3} \pi r^2 h$ Curved surface area of cone = $\pi r l$</p> 	<p>Volume of prism = area of cross section \times length</p> 
<p>Volume of cylinder = $\pi r^2 h$ Curved surface area of cylinder = $2\pi r h$</p> 	<p>Volume of sphere = $\frac{4}{3} \pi r^3$ Surface area of sphere = $4\pi r^2$</p> 

DO NOT WRITE IN THIS AREA

DO NOT WRITE IN THIS AREA

DO NOT WRITE IN THIS AREA



DO NOT WRITE IN THIS AREA

DO NOT WRITE IN THIS AREA

DO NOT WRITE IN THIS AREA

Answer ALL TWENTY FOUR questions.

Write your answers in the spaces provided.

You must write down all the stages in your working.

- 1 The table shows information about the heights, in cm, of 48 sunflowers in a garden centre.

Height of sunflower (h cm)	Frequency
$90 < h \leq 100$	8
$100 < h \leq 110$	12
$110 < h \leq 120$	15
$120 < h \leq 130$	10
$130 < h \leq 140$	3

Work out an estimate for the mean height of the sunflowers.

..... cm

(Total for Question 1 is 4 marks)



- 2 Use ruler and compasses to construct the perpendicular bisector of the line DE .
You must show all your construction lines.



(Total for Question 2 is 2 marks)

DO NOT WRITE IN THIS AREA

DO NOT WRITE IN THIS AREA

DO NOT WRITE IN THIS AREA



DO NOT WRITE IN THIS AREA

DO NOT WRITE IN THIS AREA

DO NOT WRITE IN THIS AREA

3 $\mathcal{E} = \{1, 2, 3, 4, 5, 6, 7, 8, 9, 10\}$
 $A = \{2, 3, 5, 7\}$
 $B = \{4, 6, 8, 10\}$

(a) Explain why $A \cap B = \emptyset$

.....
.....
.....

(1)

$x \in \mathcal{E}$ and $x \notin A \cup B$

(b) Write down the **two** possible values of x .

.....,

(1)

Set C is such that

$A \cup B \cup C = \mathcal{E}$
 $A \cap C = \{2\}$
 $B \cap C' = \{4, 6, 10\}$

(c) List all the members of set C .

.....

(2)

(Total for Question 3 is 4 marks)



4 A cylinder has diameter 14 cm and height 20 cm.

Work out the volume of the cylinder.
Give your answer correct to 3 significant figures.

.....cm³

(Total for Question 4 is 2 marks)

DO NOT WRITE IN THIS AREA

DO NOT WRITE IN THIS AREA

DO NOT WRITE IN THIS AREA



DO NOT WRITE IN THIS AREA

DO NOT WRITE IN THIS AREA

DO NOT WRITE IN THIS AREA

5 Josh buys and sells books for a living.

He buys 120 books for £4 each.

He sells $\frac{1}{2}$ of the books for £5 each.

He sells 40% of the books for £7 each.

He sells the rest of the books for £8 each.

(a) Calculate Josh's percentage profit.

..... %
(5)

One book that Josh owns had a value of £15 on the 1st May 2019
The value of this book had increased by 20% in the last year.

(b) Find the value of the book on the 1st May 2018

£.....
(3)

(Total for Question 5 is 8 marks)



6 ABC and DEF are similar triangles.

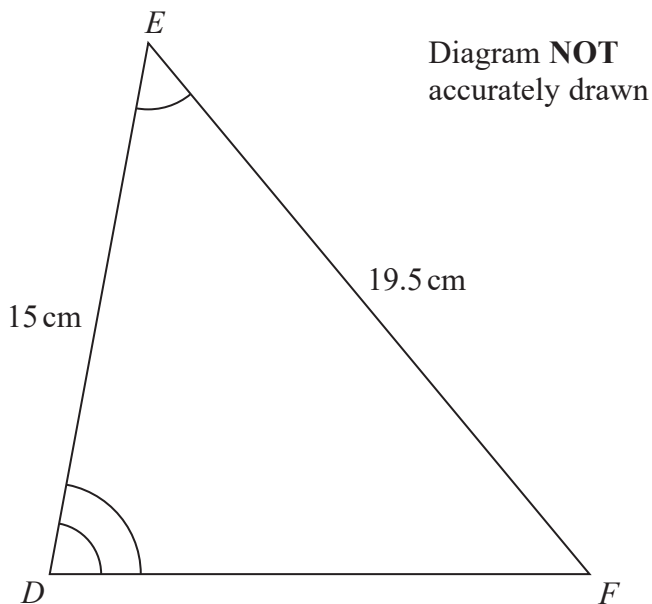
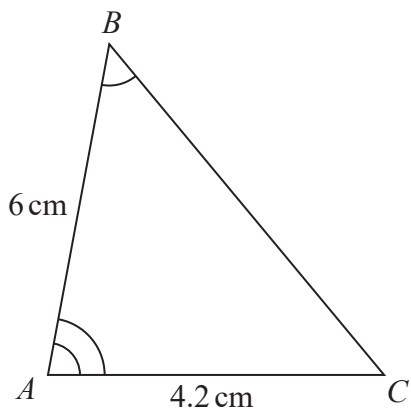

(a) Work out the length of DF .

..... cm
(2)

(b) Work out the length of BC .

..... cm
(2)

(Total for Question 6 is 4 marks)

DO NOT WRITE IN THIS AREA

DO NOT WRITE IN THIS AREA

DO NOT WRITE IN THIS AREA



DO NOT WRITE IN THIS AREA

DO NOT WRITE IN THIS AREA

DO NOT WRITE IN THIS AREA

7 30 students in a class sat a Mathematics test.
The mean mark in the test for the 30 students was 26.8

13 of the 30 students in the class are boys.
The mean mark in the test for the boys was 25

Find the mean mark in the test for the girls.
Give your answer correct to 3 significant figures.

.....
(Total for Question 7 is 3 marks)

8 Change a speed of x kilometres per hour into a speed in metres per second.
Simplify your answer.

.....m/s
(Total for Question 8 is 3 marks)



9 Solve the simultaneous equations

$$x + 2y = -0.5$$

$$3x - y = 16$$

Show clear algebraic working.

$$x = \dots\dots\dots$$

$$y = \dots\dots\dots$$

(Total for Question 9 is 3 marks)

DO NOT WRITE IN THIS AREA

DO NOT WRITE IN THIS AREA

DO NOT WRITE IN THIS AREA



DO NOT WRITE IN THIS AREA

DO NOT WRITE IN THIS AREA

DO NOT WRITE IN THIS AREA

10 The straight line **L** has gradient 5 and passes through the point with coordinates $(0, -3)$

(a) Write down an equation for **L**.

.....
(2)

(b)

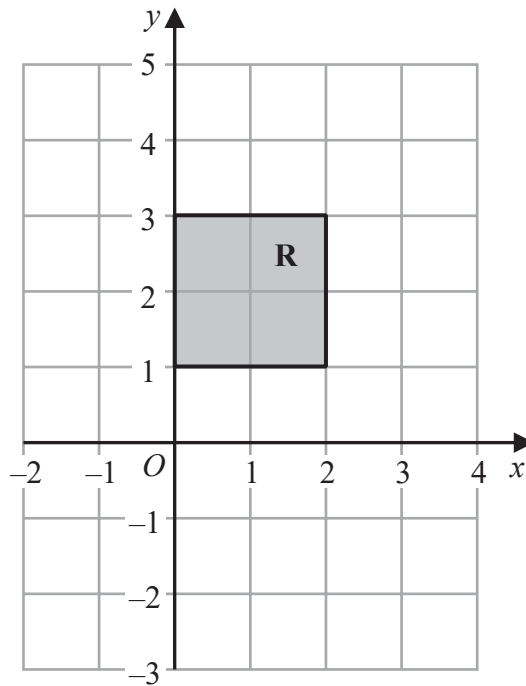

The region **R**, shown shaded in the diagram, is bounded by four straight lines.

Write down the inequalities that define **R**.

.....
(2)

(Total for Question 10 is 4 marks)



- 11 The table gives the average crowd attendance per match for each of five football clubs for one season.

Football club	Average crowd attendance
Monaco	9.5×10^3
Chelsea	4.2×10^4
Juventus	3.9×10^4
Oxford United	8.3×10^3
Barcelona	7.7×10^4

- (a) Find the difference between the average crowd attendance for Barcelona and the average crowd attendance for Monaco.
Give your answer in standard form.

.....
(2)

Antonio says,

“The average crowd attendance for Chelsea is approximately 50 times that for Oxford United.”

- (b) Is Antonio correct?
You must give a reason for your answer.

.....
.....
.....
(2)

During last season the cost of a ticket to watch Seapron United increased by 15% and then decreased by 8%

- (c) Work out the overall percentage change in the cost of a ticket to watch Seapron United during last season.

.....%

(2)

(Total for Question 11 is 6 marks)



DO NOT WRITE IN THIS AREA

DO NOT WRITE IN THIS AREA

DO NOT WRITE IN THIS AREA

12 $ABCD$ is a trapezium.

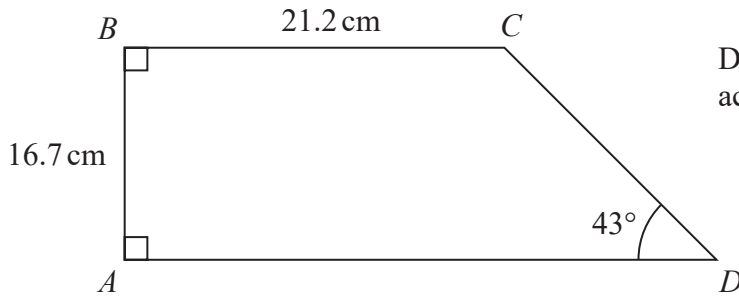

Diagram **NOT** accurately drawn

Calculate the perimeter of the trapezium.
Give your answer correct to 3 significant figures.

.....cm

(Total for Question 12 is 4 marks)



13 The table gives information about the times taken, in minutes, for 80 taxi journeys.

Time taken (t minutes)	Frequency
$0 < t \leq 5$	7
$5 < t \leq 10$	10
$10 < t \leq 15$	12
$15 < t \leq 20$	19
$20 < t \leq 25$	18
$25 < t \leq 30$	14

(a) Complete the cumulative frequency table.

Time taken (t minutes)	Cumulative frequency
$0 < t \leq 5$	
$0 < t \leq 10$	
$0 < t \leq 15$	
$0 < t \leq 20$	
$0 < t \leq 25$	
$0 < t \leq 30$	

(1)

(b) On the grid opposite, draw a cumulative frequency graph for your table.



DO NOT WRITE IN THIS AREA

DO NOT WRITE IN THIS AREA

DO NOT WRITE IN THIS AREA

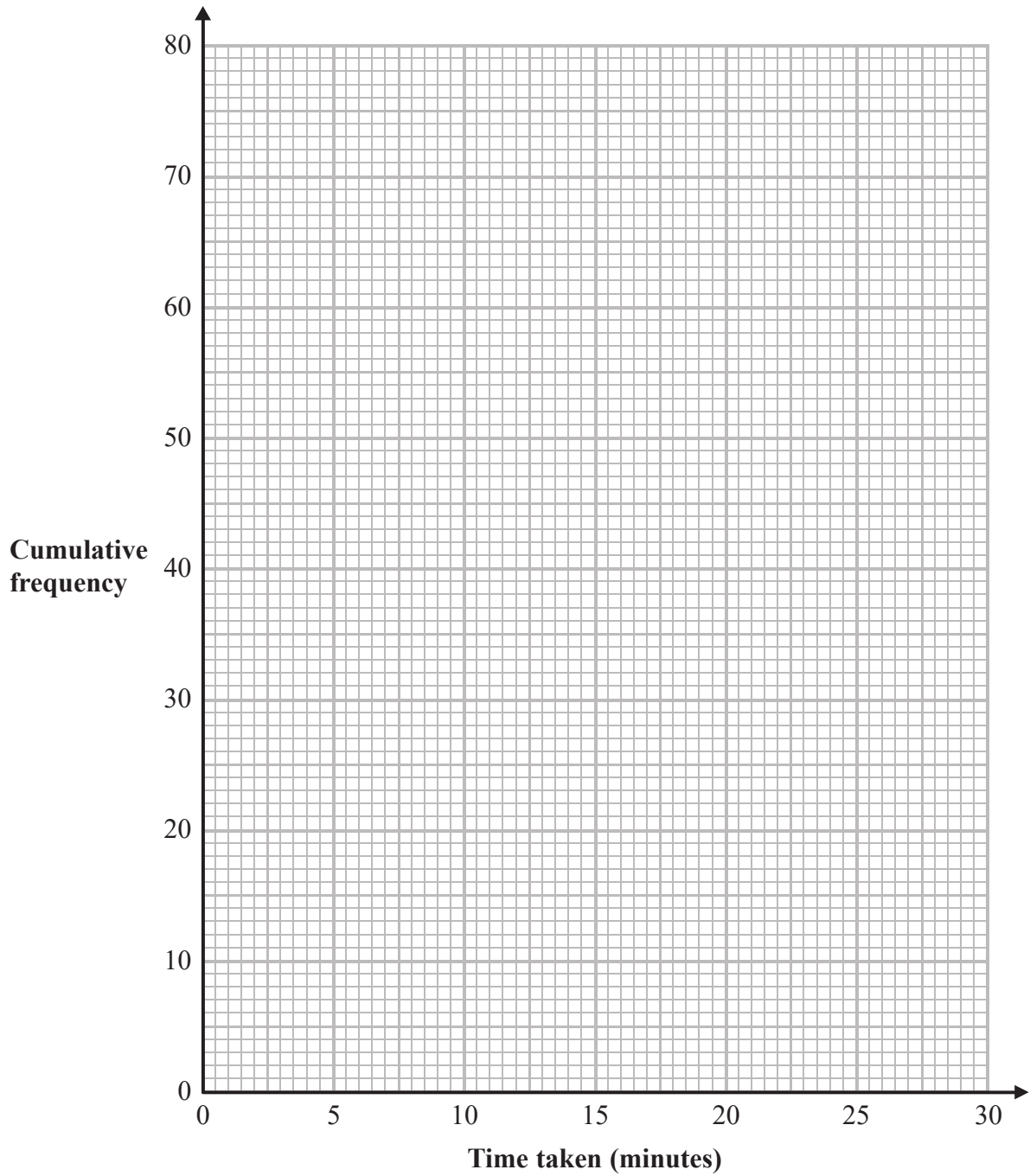

(2)

(c) Use your graph to find an estimate for the median.

.....minutes
(1)

(d) Use your graph to find an estimate for the interquartile range.

.....minutes
(2)

(Total for Question 13 is 6 marks)



14 Here are two vectors.

$$\vec{AB} = \begin{pmatrix} 6 \\ -9 \end{pmatrix} \quad \vec{CB} = \begin{pmatrix} 1 \\ 3 \end{pmatrix}$$

Find the magnitude of \vec{AC} .

.....
(Total for Question 14 is 3 marks)

15 Make x the subject of the formula $y = \sqrt{\frac{3x-2}{x+1}}$

.....
(Total for Question 15 is 4 marks)



DO NOT WRITE IN THIS AREA

DO NOT WRITE IN THIS AREA

DO NOT WRITE IN THIS AREA

16 Show that $\frac{4 + \sqrt{8}}{\sqrt{2} - 1}$ can be written in the form $a + b\sqrt{2}$, where a and b are integers.

Show each stage of your working clearly and give the value of a and the value of b .

(Total for Question 16 is 3 marks)



17 y is directly proportional to the cube of x
 $y = 20h$ when $x = h$ ($h \neq 0$)

(a) Find a formula for y in terms of x and h

$$y = \dots\dots\dots (3)$$

(b) Find x in terms of h when $y = 67.5h$
Give your answer in its simplest form.

$$x = \dots\dots\dots (2)$$

(Total for Question 17 is 5 marks)

DO NOT WRITE IN THIS AREA

DO NOT WRITE IN THIS AREA

DO NOT WRITE IN THIS AREA



DO NOT WRITE IN THIS AREA

DO NOT WRITE IN THIS AREA

DO NOT WRITE IN THIS AREA

18 The diagram shows a solid cuboid.

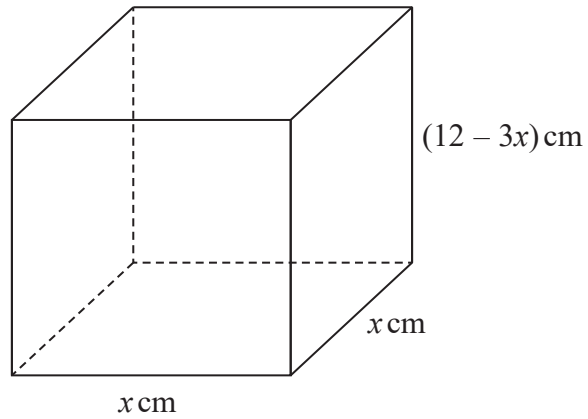

Diagram **NOT** accurately drawn

The total surface area of the cuboid is A cm²

Find the maximum value of A .

(Total for Question 18 is 5 marks)



19 $ABCD$ is a quadrilateral.

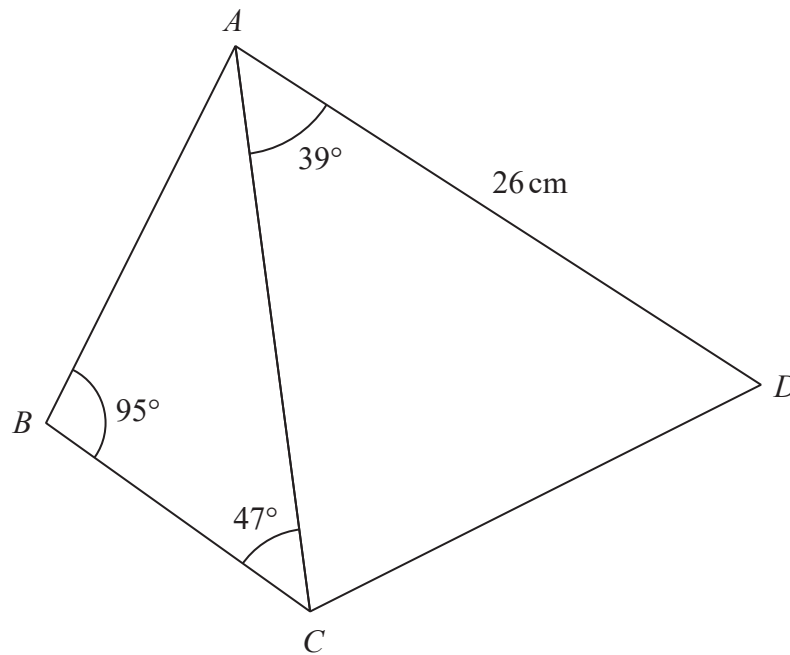

Diagram **NOT** accurately drawn

The area of triangle ACD is 250 cm^2

Calculate the area of the quadrilateral $ABCD$.

Show your working clearly.

Give your answer correct to 3 significant figures.

DO NOT WRITE IN THIS AREA

DO NOT WRITE IN THIS AREA

DO NOT WRITE IN THIS AREA



DO NOT WRITE IN THIS AREA

DO NOT WRITE IN THIS AREA

DO NOT WRITE IN THIS AREA

.....cm²

(Total for Question 19 is 6 marks)



DO NOT WRITE IN THIS AREA

DO NOT WRITE IN THIS AREA

DO NOT WRITE IN THIS AREA

20 The equation of the line **L** is $y = 9 - x$
The equation of the curve **C** is $x^2 - 3xy + 2y^2 = 0$

L and **C** intersect at two points.

Find the coordinates of these two points.
Show clear algebraic working.

(.....,) and (.....,)

(Total for Question 20 is 5 marks)



DO NOT WRITE IN THIS AREA

DO NOT WRITE IN THIS AREA

DO NOT WRITE IN THIS AREA

21 The diagram shows cuboid $ABCDEFGH$.

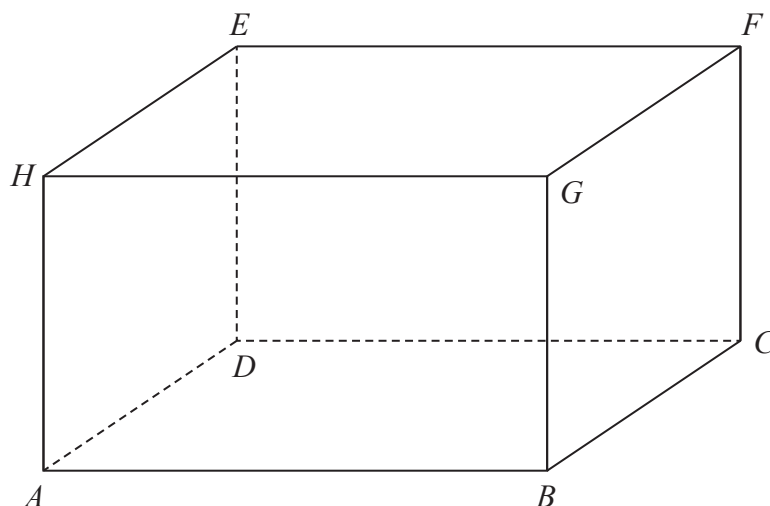

Diagram **NOT** accurately drawn

For this cuboid

the length of AB : the length of BC : the length of $CF = 4 : 2 : 3$

Calculate the size of the angle between AF and the plane $ABCD$.

Give your answer correct to one decimal place.

(Total for Question 21 is 3 marks)



22 Simplify fully $\frac{6x^3 + 13x^2 - 5x}{4x^2 - 25}$

DO NOT WRITE IN THIS AREA

DO NOT WRITE IN THIS AREA

DO NOT WRITE IN THIS AREA

(Total for Question 22 is 3 marks)



DO NOT WRITE IN THIS AREA

DO NOT WRITE IN THIS AREA

DO NOT WRITE IN THIS AREA

23 Boris has a bag that only contains red sweets and green sweets.

Boris takes at random 2 sweets from the bag.

The probability that Boris takes exactly 1 red sweet from the bag is $\frac{12}{35}$

Originally there were 3 red sweets in the bag.

Work out how many green sweets there were originally in the bag.
Show your working clearly.

.....
(Total for Question 23 is 5 marks)



24 The function f is such that $f(x) = 3x - 2$

(a) Find $f(5)$

.....
(1)

The function g is such that $g(x) = 2x^2 - 20x + 9$ where $x \geq 5$

(b) Express the inverse function g^{-1} in the form $g^{-1}(x) = \dots$

$g^{-1}(x) = \dots$
(4)

(Total for Question 24 is 5 marks)

TOTAL FOR PAPER IS 100 MARKS



DO NOT WRITE IN THIS AREA

DO NOT WRITE IN THIS AREA

DO NOT WRITE IN THIS AREA

BLANK PAGE



DO NOT WRITE IN THIS AREA

DO NOT WRITE IN THIS AREA

DO NOT WRITE IN THIS AREA

BLANK PAGE

